

THE INFORMATION CONTAINED IN THIS DRAWING IS THE SOLE PROPERTY OF HARDWARE RESOURCES INC. ANY REPRODUCTION IN PART OR AS A WHOLE WITHOUT THE WRITTEN PERMISSION OF HARDWARE RESOURCES INC. IS PROHIBITED.

R E V I S I O N S				
ECO	REV	DESCRIPTION	DATE	APPROVED

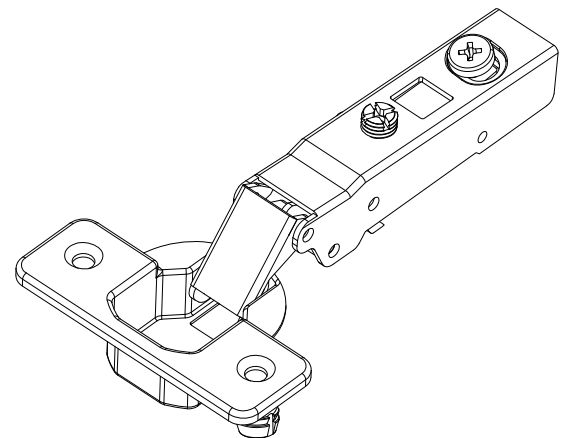
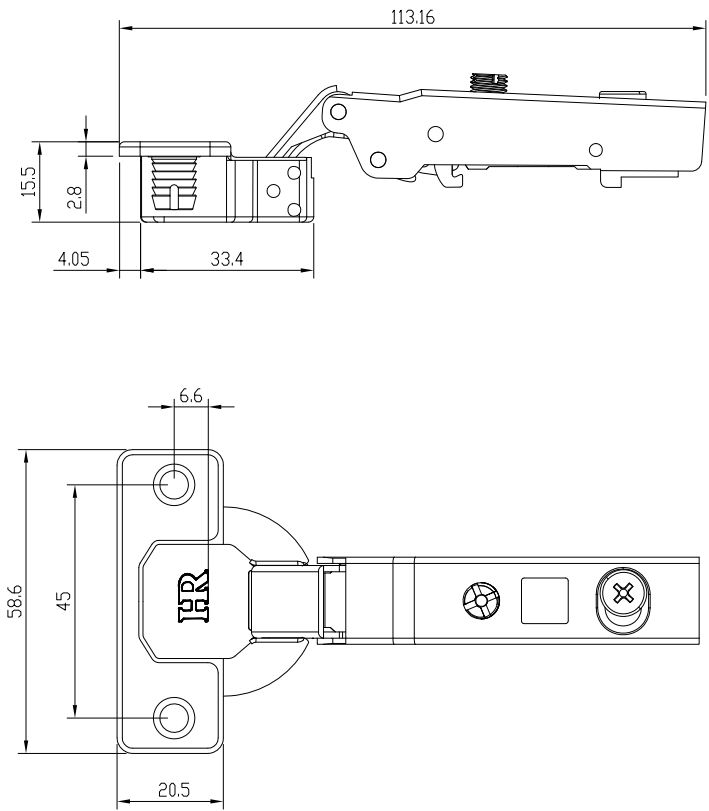

- NOTES:
1. DRAWN IN ACCORDANCE WITH ASME Y14.5M
 2. REMOVE ALL BURRS AND SHARP EDGES
 3. ALL FILLETS AND ROUNDS R 0.05 UNLESS OTHERWISE SPECIFIED
 4. 125° HEAVY DUTY CLIP ON CAM ADJUST.
 5. OMM CRANK, BRIGHT NICKEL ARM, WHITE DOWELS.

UNLESS OTHERWISE SPECIFIED DIM ARE IN MILLIMETERS (mm)	
GENERAL TOLERANCES	
0.00 - 14.99	± 0.10
15.00 - 39.99	± 0.20
40.00 - 74.99	± 0.30
75.00 - 99.99	± 0.45
100.00 - 199.99	± 0.70
200.00 - 299.99	± 1.00
300.00 -	± 1.10
ANGLE	± 1.0°

THIRD ANGLE PROJECTION	
MATERIAL	FINISH
STEEL	Zinc
DRAWN BY	DATE
Alexander.W	11-02-15
DESIGNED BY	DATE
APPROVED BY	DATE

hardware resources

TITLE

725.0U84.05

DRAWING NUMBER	REV
725.0U84.05	proj_revision
SIZE	RELEASE LEVEL
A3	SCALE 1:1
SHEET	1 OF 1